

Experience-dependent plasticity in pitch encoding: from brainstem to auditory cortex

Ananthanarayan Krishnan^a, Jackson Thomas Gandour^a
and Gavin M. Bidelman^b

Linguistic and musical pitch provide an analytic window to evaluate how neural representations of important pitch attributes of a sound undergo transformation from early sensory to later cognitive stages of processing in the human brain, and how pitch-relevant experience shapes these representations. These pitch attributes are shaped differentially depending on their functional relevance to a listener. Neural encoding of pitch-relevant information is shaped by the perceptual salience of domain-specific features at subcortical (auditory brainstem) and cortical stages of processing. The emergence of a functional ear asymmetry in the neural encoding of pitch-relevant information at a lower sensory processing level supports the view that local and feedforward and feedback mechanisms are involved in pitch-relevant processing. A theoretical framework for a neural network is proposed involving coordination between local, feedforward, and

feedback components that can account for experience-induced enhancement of pitch representations at multiple levels of the auditory pathway. *NeuroReport* 23:498–502 © 2012 Wolters Kluwer Health | Lippincott Williams & Wilkins.

NeuroReport 2012, 23:498–502

Keywords: auditory brainstem, experience-dependent plasticity, feedback, feedforward, frequency following response, functional ear asymmetry, language, mismatch negativity, music, pitch

^aDepartment of Speech Language Hearing Sciences, Purdue University, West Lafayette, Indiana, USA and ^bRotman Research Institute, Baycrest, Toronto, Ontario, Canada

Correspondence to Ananthanarayan Krishnan, Purdue University, Department of Speech Language Hearing Sciences, 1353 Heavilon Hall, 500 Oval Drive, West Lafayette, IN 47907-2038 USA
Tel: +1 765 494 3793; fax: +1 765 494 0771; e-mail: rkrish@purdue.edu

Received 26 January 2012 accepted 7 March 2012

Introduction

Hierarchical nature of pitch processing

Pitch is an important information-bearing perceptual component of language and music. As such, it provides an excellent window for studying experience-dependent effects on both cortical and brainstem components of a well-coordinated, hierarchical processing network. It is our view that a complete understanding of the neural organization of language and music can be achieved only by viewing these processes as a set of hierarchical computations. These computations are applied to representations at different stages of processing and are driven by experience-dependent sensitivity to linguistically/musically relevant features or dimensions. There is growing empirical evidence to support the notion that the neural representation of pitch-relevant information at both brainstem and cortical levels of processing is influenced by one's experience with language (or music) [1,2]. The neural mechanisms governing such experience-dependent plasticity are likely mediated by a coordinated interplay between ascending and descending neural pathways [3]. Physiological evidence from animal studies shows that signal representation in subcortical structures can be modulated by the efferent corticofugal system [4]. Evidence from evoked potentials suggests that enhanced subcortical activity in humans may also be mediated by the corticofugal system in those individuals with long-term experience in the language [5] or music domain [6], and even those with short-term language training [7]. A

correlation between brainstem and cortical responses in musicians suggest that brainstem neural representations of pitch and cortical response timing are shaped in a coordinated manner through corticofugal modulation of subcortical afferent circuitry [8].

However, little is known about how language experience or musical training shapes pitch processing at each stage of this processing hierarchy. This review focuses primarily on electrophysiological studies of sensory stages of pitch processing in the brainstem and the auditory cortex (AC). Experience-dependent effects that are related to listeners' domain of pitch expertise are argued to be compatible with a theoretical model that encapsulates local, feedback, and feedforward components in a neural network. On the basis of empirical evidence, we propose a theoretical framework to account for experience-dependent enhancement of pitch encoding in the brainstem and in the AC.

Features of pitch perception in tone languages

In tonal languages, voice fundamental frequency (f_0) features (e.g. height, direction, slope) provide the dominant cue for high intelligibility of lexical tones [9]. We argue that f_0 features, as opposed to categories, are essential for a better understanding of subcortical and early cortical stages of tone perception. In contrast to information relevant to morphology, syntax, semantics, and pragmatics, we assume that the shaping of pitch-related

information relevant to tone perception begins well before the auditory signal reaches the cerebral cortex. Using multidimensional scaling analysis of paired dissimilarity ratings of pitch stimuli [10], we find that such features underlie a common perceptual space, and that they are differentially weighted depending on the configuration of pitch patterns and their phonological relationship to one another in a listener's native tone space (cf. Huang and Johnson [11]). Having established that behavioral weighting of pitch cues varies as a function of language experience, it seems reasonable to expect corresponding effects of such features at multiple stages of processing along the auditory pathway.

Response characteristics of brainstem-evoked potentials related to pitch

The scalp recorded frequency following response (FFR) reflects sustained phase-locked neural activity in a population of neural elements within the rostral brainstem [12] that can be easily recorded between scalp electrodes placed at the high forehead and the seventh cervical vertebra (C7). FFRs faithfully follow the temporal and spectral characteristics of the stimulus that can be extracted by frequency domain spectral and time domain autocorrelation analyses, respectively [5,13]. FFRs preserve spectrotemporal information related to the pitch of steady-state [14] and dynamic complex sounds in speech [5,13] and nonspeech stimuli [15–17]. Importantly, the encoding of pitch information preserved in the FFR is strongly correlated with perceptual measures [18,19]. These findings suggest that acoustic features relevant to pitch perception are well represented in the neural representations at the level of the brainstem.

Evidence from brainstem-evoked potentials

We argue that the emergence of acoustic-phonetic features relevant to tone perception begins no later than 5–8 ms from the time the auditory signal enters the ear. FFRs preserve pitch information of lexical tones in both native and non-native listeners. However, they are more robust in the former because of long-term exposure to their native pitch contours [5]. We therefore conclude that early sensory encoding of pitch information below the cerebral cortex is sensitive to language experience. No matter speech or nonspeech stimuli, pitch encoding is enhanced in the brainstem of Chinese listeners as compared with English [5,17]. Moreover, we find that Chinese exhibit more robust pitch representation precisely in those short portions of Mandarin tones that contain rapid changes in pitch movement [16].

With respect to pitch features, brainstem encoding of rising contours is found to be most important in separating Chinese listeners from listeners of nontone languages [20]. Pitch features important to tone perception are also found to be more resistant to degraded

listening conditions in Mandarin listeners [21]. These advantages in encoding, however, diminish as the f_0 rate of change within a pitch contour moves beyond what occurs in natural speech [22]. We conclude that experience-dependent neuroplasticity is primarily restricted to stimuli that are of functional relevance to the listener. Indeed, a strong correlation between neural and behavioral measures corroborates the view that pitch encoding at a subcortical, sensory level of processing plays an important role in shaping tone perception [19].

Language-dependent encoding mechanisms in the brainstem are especially sensitive to the curvilinear shape of pitch contours that occur in natural speech. Language-dependent effects do not occur no matter how closely a rising or falling linear pitch pattern approximates a Mandarin tone [15,23]. A non-native, curvilinear pitch pattern similarly fails to elicit a language-dependent effect [15]. Thus, experience-dependent effects in the brainstem are highly sensitive to specific features of pitch patterns in one's native language.

In the music domain, the brainstem is sensitive to individuals' long-term exposure to specific timbres. For example, pianists' responses reflect the timbral characteristics of piano sounds with greater fidelity than those of non-pianists [24]. In the language domain, pitch encoding may similarly be influenced by the linguistic status of timbre. Indeed, f_0 magnitudes were larger when co-occurring with a native as compared with a non-native vowel quality [25]. Such experience-dependent effects suggest that subcortical sensory encoding of pitch interacts with timbre in the human brainstem.

Experience-dependent pitch encoding is shaped by specific acoustic features within a particular domain

Long-term music training acts to enhance the magnitude and precision with which the brainstem responds to musical pitch [26,27]. These brain indices are correlated with an individual's degree of training/experience [6] and, assuming that the stimuli and task are behaviorally relevant to the listener, their perceptual performance [28,29]. Such findings illustrate the interaction between one's pitch experience, brain physiology, and perception.

Our comparisons between the language and the music domains reveal overall enhancements in brainstem FFRs elicited by either musical or linguistic pitch patterns in musicians and tone language speakers alike [26,28]. Thus, long-term pitch experience seems to improve the brain's ability to encode pitch regardless of the domain of expertise. Yet, these sensory representations are subject to further 'tuning' according to specific acoustic features encountered in a listener's experience. Musicians, for example, show enhanced responses when pitch patterns intersect discrete notes along the musical scale, and tone language speakers, in contrast, during rapidly changing portions of tonal contours [26,30]. Such cue weighting is

consistent with the relative importance of these perceptual dimensions in their respective domains. These findings collectively lead us to infer that both language and musical experience provide some mutual benefit to the neural extraction of pitch, but that specific features of the acoustic signal are highlighted in subcortical responses depending on their perceptual salience and function within a listener's domain of expertise.

Language-dependent ear (a)symmetries related to perceptual features of pitch emerge in the brainstem

Hemispheric laterality for cortical speech processing is predictable on the basis of low-level, spectral and temporal features, but at the same time may be modulated by high-level, abstract linguistic functions [31]. By virtue of fixed, structural asymmetries in the auditory pathway, monaural stimulation of either the left or the right ear primarily drives the inferior colliculus and AC on the contralateral side. These structural asymmetries make it possible to ask whether ear asymmetries in pitch encoding at the level of the brainstem can similarly be modulated by functional properties of pitch.

Ear asymmetry at the level of the cochlea mimics hemispheric specialization for nonspeech signals [32]. Similarly, a functional ear asymmetry has been observed in brainstem responses depending on the linguistic status of pitch in response to left and right monaural stimulation [33]. Within a portion of a Mandarin tone that exhibits a rapid change in pitch, a larger degree of FFR rightward ear asymmetry in pitch encoding was evoked as compared with its non-native, mirror image counterpart. An asymmetry-favoring left ear stimulation was evoked by the non-native pitch contour only. No ear asymmetry was detected in response to the lexical tone. Its symmetrical response between ears may be a precursor of recruitment of higher processing structures between the left and the right cerebral hemispheres. The fact that the processing of linguistic pitch involves both hemispheres is consistent with neuroimaging studies showing that hemodynamic responses to pitch information varies between left and right perisylvian areas as a function of language experience [31]. This early shaping of the auditory signal at a preattentive, sensory level of processing is compatible with the idea that nascent representations of acoustic-phonetic features may emerge early along the auditory pathway.

Evidence from cortical-evoked potentials

Early, automatic, preattentive pitch encoding is shaped by specific acoustic features within a particular domain Mismatch negativity (MMN), an automatic, preattentive cortical response, is an event-related potential with a frontal-central distribution about 150–300 ms after stimulus onset. It is well known that language experience influences the MMN response to speech sounds [34]. Of special interest to us is pitch, a multidimensional

perceptual attribute that relies on several acoustic cues or features. The MMN may serve as an index of the relative saliency of the underlying features of pitch that are differentially weighted by language or music experience.

A multidimensional scaling analysis of MMN responses to Mandarin tones revealed that native speakers of Mandarin Chinese, as compared with English, are more sensitive to pitch contour than pitch height [35,36]. However, these effects are not necessarily language specific. English-speaking musicians and native Chinese exhibited larger MMN responses relative to English nonmusicians when presented with nonspeech homologues of Mandarin tones [37]. Thus, experience-dependent effects need not be driven solely by native linguistic categories. As with FFRs, these MMN data lead us to infer that some mutual benefit is gained in the neural extraction of pitch regardless of a listener's domain of expertise.

The theoretical framework for experience-dependent neural plasticity

We propose an empirically driven, hierarchical, theoretical framework to account for experience-dependent enhancement of pitch representation in the brainstem and in the early sensory level processing in the AC (Fig. 1). This framework includes (i) local pitch mechanisms in the inferior colliculus (IC) and the AC, (ii) a feedforward component (colliculo-thalamo-cortical projections), (iii) a corticocollicular feedback component, and (iv) a corticothalamic feedback component [38].

- (1) *Pitch mechanisms in the IC and AC*: Subject to experience-dependent plasticity as a result of local reorganization by corticofugal modulation initial learning/training. Reorganization later permits pitch information to be extracted in a robust manner without on-line corticofugal influence. Feedforward, feedback, and local neuromodulatory inputs further transform the pitch representation at the cortical level. Both temporal-based and rate-based local pitch-encoding mechanisms are implicated in the auditory system.
- (2) *Ipsilateral, dominant feedforward (colliculo-thalamo-cortical)*: Projection from the IC to the AC is driven primarily by the contralateral ear, and transmits enhanced pitch-relevant information to the AC.
- (3) *Ipsilateral, dominant feedback (corticocollicular)*: Projection (part of the corticofugal system) from the cerebral cortex to the IC facilitates experience-dependent reorganization in the brainstem.
- (4) *Ipsilateral, dominant feedback (corticothalamic)*: projection transforms output from the AC to the medial geniculate body.

Behaviorally relevant stimuli are thought to activate the local, feedforward, and feedback loops in a coordinated manner at each stage of processing. Neuromodulatory

Fig. 1

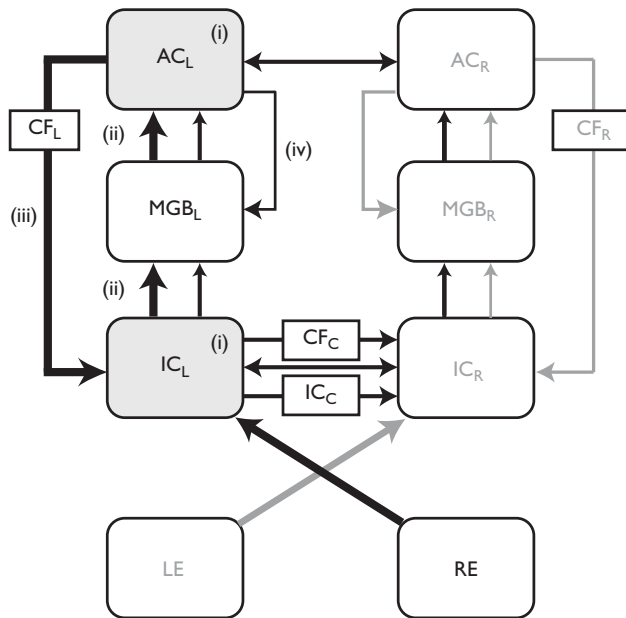

The anatomic model of the auditory pathway illustrating functional asymmetry in IC responses favoring RE stimulation, shown by the relatively thicker red lines compared with LE stimulation (blue lines). Local pitch mechanisms in the IC and the AC [gray fill; (i)] are subject to experience-dependent plasticity. For linguistically relevant sounds, this functional asymmetry is initially influenced by a corticocollicular feedback (iii) to promote reorganization in the IC for perceptual learning. A feedforward colliculo-thalamo-cortical component completes a core neural circuit (ii) that is known to be related to auditory learning and experience [38]. A corticothalamic feedback component (iv) further transforms output from the AC to the MGB. AC, (primary) auditory cortex; CF, corticofugal; IC, inferior colliculus (brainstem); LE, left ear; MGB, medial geniculate body (thalamus); RE, right ear; subscript _C, contralateral; subscript _L, left; subscript _R, right. At the level of the IC and AC, the solid black double arrow indicates that pitch information may be transmitted contralaterally in either direction.

inputs presumably induce large-scale, feature-specific plasticity to enhance sensory encoding. We propose that long-term experience sharpens specific pitch mechanisms in the IC and in the AC with particular sensitivity to linguistically relevant dynamic segments. Once local mechanisms are reorganized by a feedback/feedforward influence, local excitatory and inhibitory interactions that are known to play an important role in signal selection at each level of processing can presumably maintain the experience-dependent effect [39].

Conclusion

Long-term experience sharpens pitch mechanisms that are especially sensitive to linguistically relevant dynamic segments in the rostral brainstem and the AC. Across domains, language experience and musical training provide some mutual benefit to the neural extraction of pitch. However, it is also clear that neural responses are

evoked differentially by specific pitch features depending on their perceptual saliency and function within a listener's domain of expertise. This early shaping of the auditory signal at a preattentive, sensory level of processing is compatible with the idea that nascent representations of acoustic-phonetic features and hemispheric functional lateralization may emerge early along the auditory pathway. The observation of a strong correlation between neural and behavioral measures supports the view that pitch encoding at early, sensory levels of processing may play an important role in the development of pitch percepts, that is, higher-order representations that emerge at later stages in the processing hierarchy. An empirically based, hierarchical processing network involving coordination between local, feedforward, and feedback components can account for experience-induced enhancement of pitch representations at the level of the brainstem and the AC. Future experiments should aim to evaluate the nature of the interaction and functional connectivity between stages of processing in the hierarchy by a comparative evaluation of neural representations at multiple stages concurrently.

Acknowledgements

The study was supported by National Institutes of Health R01 DC008549 (A.K.).

Conflicts of interest

There are no conflicts of interest.

References

- 1 Kraus N, Banai K. Auditory-processing malleability: focus on language and music. *Curr Dir Psychol Sci* 2007; **16**:105–110.
- 2 Krishnan A, Gandour JT. The role of the auditory brainstem in processing linguistically-relevant pitch patterns. *Brain Lang* 2009; **110**:135–148.
- 3 Chandrasekaran B, Kraus N. The scalp-recorded brainstem response to speech: neural origins and plasticity. *Psychophysiology* 2010; **47**:236–246.
- 4 Suga N, Ma X, Gao E, Sakai M, Chowdhury SA. Descending system and plasticity for auditory signal processing: neuroethological data for speech scientists. *Speech Commun* 2003; **41**:189–200.
- 5 Krishnan A, Xu Y, Gandour JT, Cariani P. Encoding of pitch in the human brainstem is sensitive to language experience. *Brain Res Cogn Brain Res* 2005; **25**:161–168.
- 6 Wong PC, Skoe E, Russo NM, Dees T, Kraus N. Musical experience shapes human brainstem encoding of linguistic pitch patterns. *Nat Neurosci* 2007; **10**:420–422.
- 7 Song JH, Skoe E, Wong PCM, Kraus N. Plasticity in the adult human auditory brainstem following short-term linguistic training. *J Cogn Neurosci* 2008; **20**:1892–1902.
- 8 Musacchia G, Strait D, Kraus N. Relationships between behavior, brainstem and cortical encoding of seen and heard speech in musicians and non-musicians. *Hear Res* 2008; **241**:34–42.
- 9 Gandour JT. Phonetics of tone. In: Asher R, Simpson J, editors. *The encyclopedia of language & linguistics*. New York: Pergamon Press. 1994. pp. 3116–3123.
- 10 Gandour JT. Tone perception in far Eastern languages. *J Phon* 1983; **11**:149–175.
- 11 Huang T, Johnson K. Language specificity in speech perception: perception of Mandarin tones by native and non-native listeners. *Phonetica* 2011; **67**:243–267.
- 12 Glaser EM, Suter CM, Dasheiff R, Goldberg A. The human frequency-following response: its behavior during continuous tone and tone burst stimulation. *Electroencephalogr Clin Neurophysiol* 1976; **40**:25–32.

- 13 Krishnan A, Xu Y, Gandour JT, Cariani PA. Human frequency-following response: representation of pitch contours in Chinese tones. *Hear Res* 2004; **189**:1–12.
- 14 Krishnan A, Plack CJ. Neural encoding in the human brainstem relevant to the pitch of complex tones. *Hear Res* 2011; **275**:110–119.
- 15 Krishnan A, Gandour JT, Bidelman GM, Swaminathan J. Experience-dependent neural representation of dynamic pitch in the brainstem. *NeuroReport* 2009; **20**:408–413.
- 16 Krishnan A, Swaminathan J, Gandour JT. Experience-dependent enhancement of linguistic pitch representation in the brainstem is not specific to a speech context. *J Cogn Neurosci* 2009; **21**:1092–1105.
- 17 Swaminathan J, Krishnan A, Gandour JT. Pitch encoding in speech and nonspeech contexts in the human auditory brainstem. *NeuroReport* 2008; **19**:1163–1167.
- 18 Bidelman GM, Krishnan A. Brainstem correlates of behavioral and compositional preferences of musical harmony. *NeuroReport* 2011; **22**:212–216.
- 19 Krishnan A, Bidelman GM, Gandour JT. Neural representation of pitch salience in the human brainstem revealed by psychophysical and electrophysiological indices. *Hear Res* 2010; **268**:60–66.
- 20 Krishnan A, Gandour JT, Bidelman GM. The effects of tone language experience on pitch processing in the brainstem. *J Neurolinguistics* 2010; **23**:81–95.
- 21 Krishnan A, Gandour JT, Bidelman GM. Brainstem pitch representation in native speakers of Mandarin is less susceptible to degradation of stimulus temporal regularity. *Brain Res* 2010; **1313**:124–133.
- 22 Krishnan A, Gandour JT, Smalt CJ, Bidelman GM. Language-dependent pitch encoding advantage in the brainstem is not limited to acceleration rates that occur in natural speech. *Brain Lang* 2010; **114**:193–198.
- 23 Xu Y, Krishnan A, Gandour JT. Specificity of experience-dependent pitch representation in the brainstem. *NeuroReport* 2006; **17**:1601–1605.
- 24 Strait DL, Chan K, Ashley R, Kraus N. Specialization among the specialized: auditory brainstem function is tuned in to timbre. *Cortex* 2012; **48**:360–362.
- 25 Krishnan A, Gandour JT, Ananthakrishnan S, Bidelman GM, Smalt CJ. Linguistic status of timbre influences pitch encoding in the brainstem. *NeuroReport* 2011; **22**:801–803.
- 26 Bidelman GM, Gandour JT, Krishnan A. Cross-domain effects of music and language experience on the representation of pitch in the human auditory brainstem. *J Cogn Neurosci* 2011; **23**:425–434.
- 27 Bidelman GM, Krishnan A, Gandour JT. Enhanced brainstem encoding predicts musicians' perceptual advantages with pitch. *Eur J Neurosci* 2011; **33**:530–538.
- 28 Bidelman GM, Gandour JT, Krishnan A. Musicians and tone-language speakers share enhanced brainstem encoding but not perceptual benefits for musical pitch. *Brain Cogn* 2011; **77**:1–10.
- 29 Bidelman GM, Krishnan A. Effects of reverberation on brainstem representation of speech in musicians and non-musicians. *Brain Res* 2010; **1355**:112–125.
- 30 Bidelman GM, Gandour JT, Krishnan A. Musicians demonstrate experience-dependent brainstem enhancement of musical scale features within continuously gliding pitch. *Neurosci Lett* 2011; **503**:203–207.
- 31 Zatorre RJ, Gandour JT. Neural specializations for speech and pitch: moving beyond the dichotomies. *Philos Trans R Soc Lond B Biol Sci* 2008; **363**:1087–1104.
- 32 Sininger YS, Cone-Wesson B. Asymmetric cochlear processing mimics hemispheric specialization. *Science* 2004; **305**:1581.
- 33 Krishnan A, Gandour JT, Ananthakrishnan S, Bidelman GM, Smalt CJ. Functional ear (a)symmetry in brainstem neural activity relevant to encoding of voice pitch: a precursor for hemispheric specialization? *Brain Lang* 2011; **119**:226–231.
- 34 Naatanen R. The perception of speech sounds by the human brain as reflected by the mismatch negativity (MMN) and its magnetic equivalent (MMNm). *Psychophysiology* 2001; **38**:1–21.
- 35 Chandrasekaran B, Gandour JT, Krishnan A. Neuroplasticity in the processing of pitch dimensions: a multidimensional scaling analysis of the mismatch negativity. *Restor Neurol Neurosci* 2007; **25**:195–210.
- 36 Chandrasekaran B, Krishnan A, Gandour JT. Mismatch negativity to pitch contours is influenced by language experience. *Brain Res* 2007; **1128**:148–156.
- 37 Chandrasekaran B, Krishnan A, Gandour JT. Relative influence of musical and linguistic experience on early cortical processing of pitch contours. *Brain Lang* 2009; **108**:1–9.
- 38 Xiong Y, Zhang Y, Yan J. The neurobiology of sound-specific auditory plasticity: a core neural circuit. *Neurosci Biobehav Rev* 2009; **33**:1178–1184.
- 39 Langner G. Periodicity coding in the auditory system. *Hear Res* 1992; **60**:115–142.